

How Various Time Delays are Obtained

Generally speaking, the trip time of a time delay magnetic circuit breaker is directly related to the length of time it takes for the moving metal core to move to the fully “in” position. If the delay tube is filled with air, the core will move rather quickly, and the breaker will trip quickly. This is characteristic of the Ultrashort Delay Curves #11 and #21. Solid state devices, which cannot tolerate even short periods of current overload, should use Instantaneous Curves #10, #20 and #30. These curves have no intentional time delay.

When the delay tube is filled with a light viscosity (temperature stable) fluid (Fig. 5), the core's travel to the

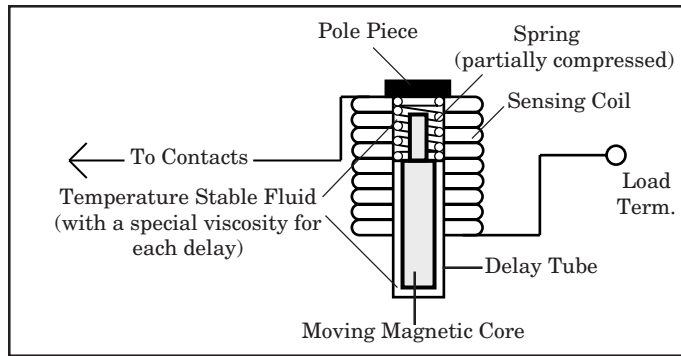

Figure 5

full “in” position will be intentionally delayed. This results in the slightly longer Medium Delays #14 and #24, which are used for general purpose applications.

When a heavy viscosity fluid is used, the result will be a very long delay, such as Delay Curve #16, #26, #36 or #46. These curves are commonly used in motor applications to minimize the potential for nuisance tripping during lengthy motor start-ups.

By use of magnetic “shunt” plates within the magnetic circuit, it is possible to divert magnetic flux resulting in higher “inrush withstanding capability” (or high inrush delays). These delays disregard short duration, high pulse surges (typically 8ms or less and up to 25x rated current), characteristic of transformers, switching power supplies and capacitive loads. Delay Curves #42, #44, and #46, are available for these applications.

Hydraulic delay protectors have the added advantage of tripping slightly sooner when operating in higher temperature conditions and slightly longer when cold. This characteristic mirrors the protection needs in most applications. Note that the current required to trip the breaker does not change, just the time delay for tripping.

Available Circuit Options

Series Trip

A basic two terminal device usually used as a combination power switch and overload protector. The contacts and current sensing coil are connected in series with the line and load terminals.

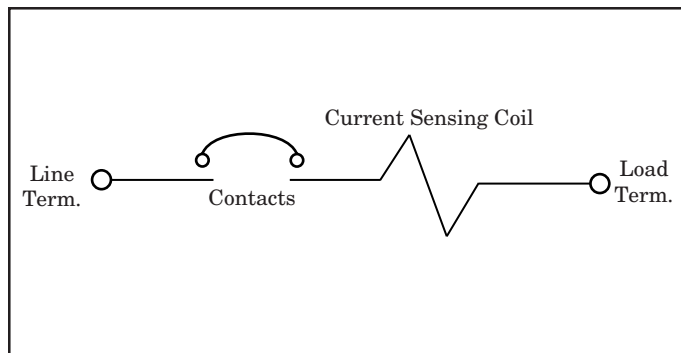

Series Trip with Auxiliary Switch

Same as a Series Trip except with the addition of a S.P.D.T. snap-action switch, which is electrically isolated, but mechanically linked to the movement of the main breaker contacts. This switch is commonly used to remotely signal the status of the breaker (ON or OFF/TRIPPED).

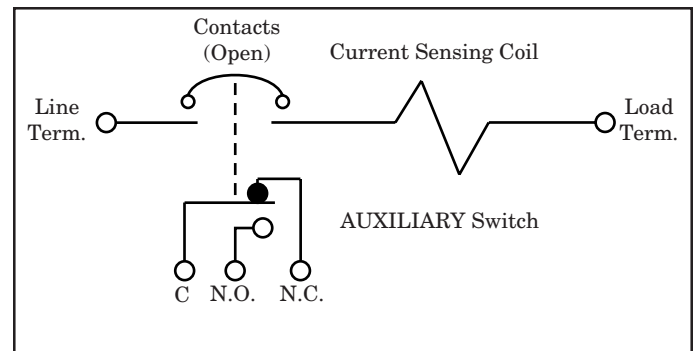

(B&C Series Orientation Shown)

Available Circuit Options (Cont.)

Series Mid-Trip with Auxiliary/Alarm Switch

Similar to "Series Trip with Auxiliary Switch" except the S.P.D.T. auxiliary switch is actuated ONLY UPON THE ELECTRICAL TRIP OF THE BREAKER. Upon electrical trip, the "N.O." contact closes and the "N.C." contact opens. This can be used to remotely signal the "TRIPPED" status of the breaker. Also, upon electrical trip, the handle moves to the "MID" position as opposed to the "full off" position typical of other breakers. This gives a specific visual panel indication of a "TRIPPED" breaker as compared to one which is merely turned OFF.

Series Mid-Trip is also available without Auxiliary/Alarm Switch.

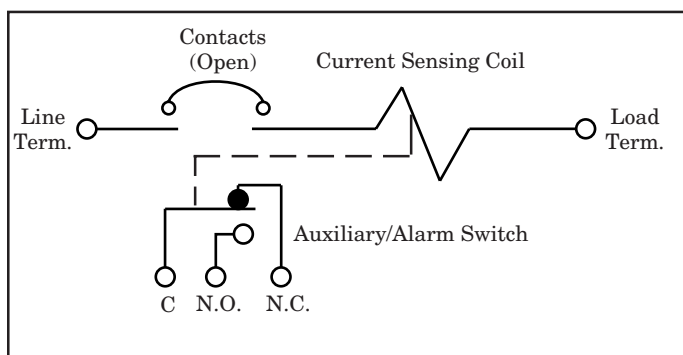

Series Trip with Remote Shutdown

(For "dump" circuit or "panic" circuit applications)
Same as a Series Trip but with an additional (self-interrupting) "voltage coil" pole (usually of opposite polarity) for remote shutdown. In the example, a momentary voltage pulse to Pole 2 will shut down both Pole 1 and Pole 2. Because the voltage coil in Pole 2 is self-interrupting, no additional components, such as auxiliary switches, etc., are required in that circuit. Approximately 4 watts minimum is required to activate the voltage coil pole. This extra pole configuration is usually required by World Approval Agencies. Consult factory for this circuit.

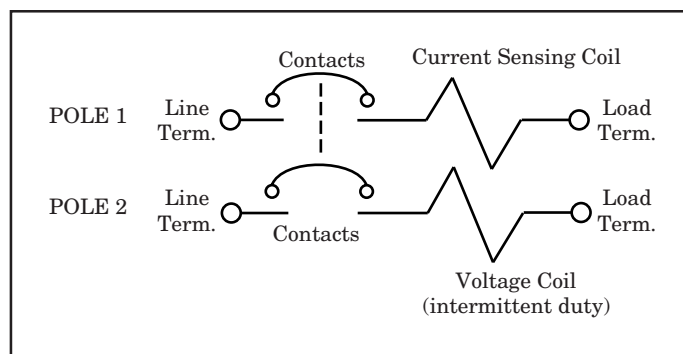

Dual Coil with Remote Shutdown

Similar to "Series Trip with Remote Shutdown" except an extra pole is NOT required. A Dual Coil breaker has two coils in the space normally occupied by a single coil. A current coil is used for overload protection and the instant trip voltage coil can be used for remote shutdown. Approximately 30 watts minimum is required to activate this type of voltage coil.

Two Dual Coil options are available. The most common is the "Relay Trip Dual Coil", a four terminal device in which the voltage coil circuit is electrically isolated from the current coil circuit. This allows the triggering of the voltage coil from an independent voltage source separate from line voltage. As such, a DC pulse to the voltage coil can be used to shutdown a primary high energy AC circuit. However, because voltage coils are rated for intermittent duty, provisions must be made to disconnect the power source from the voltage coil after tripping.

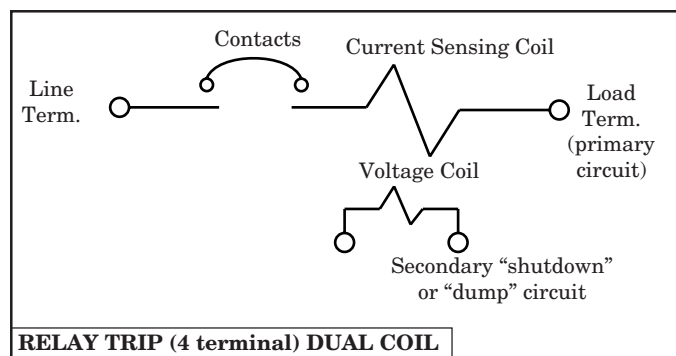

The other circuit option is the "Shunt Trip Dual Coil", a three terminal device with one side of the voltage coil internally connected to the primary circuit. The other side of the voltage coil is connected to an external third terminal on the bottom of the breaker. This circuit option uses line voltage for dual coil activation, saving wiring costs and resulting in a self-protecting voltage coil.

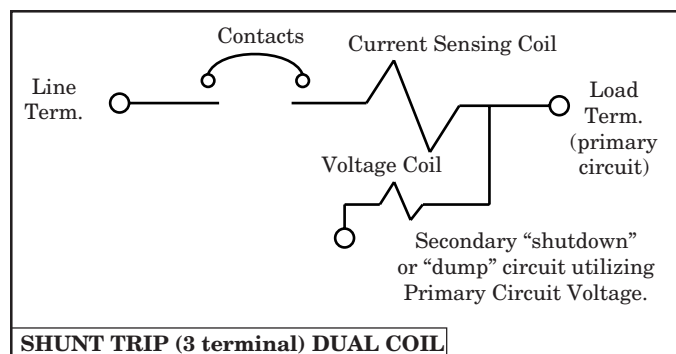

Care must be taken to avoid mis-wiring of the primary and secondary (voltage coil) circuits. Mis-wiring could lead to damage to the voltage coil and/or its power source. Consult factory for all Dual Coil applications.

Switch Only

Same as a Series Trip, but without a sensing coil. Provides low cost, heavy-duty switch capability when overload protection is not needed. "Switch Only" is available with and without an auxiliary switch.

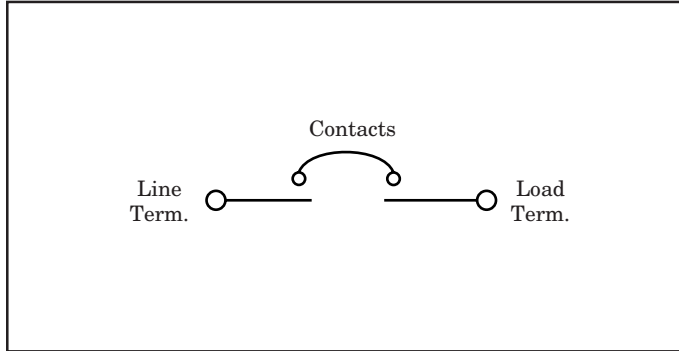

Relay Trip

A four terminal device in which the contact and coil circuits are electrically isolated but mechanically linked. An overload in the coil circuit will cause the contact circuit to open. These circuits may be of opposite polarity. Commonly used in dump circuit, panic circuit, and remote shutdown applications. (Note: World Approval Agencies may require a more electrically isolated voltage coil pole for this function - Ref. "Series Trip with Remote Shutdown" circuit option.)

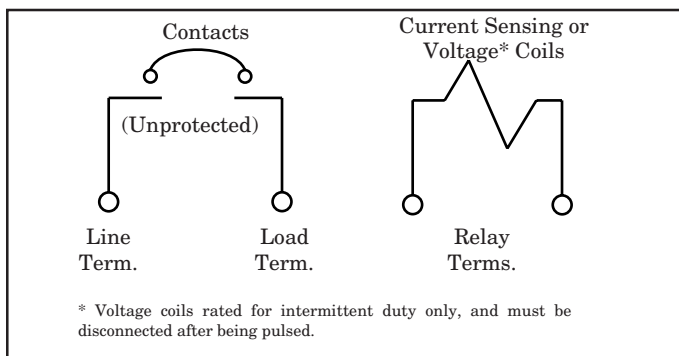

Shunt Trip

A three terminal device similar to "Series Trip", but with the addition of a third terminal between the contacts and the coil. This circuit is usually used to control two separate loads (A&B) from the same power source, while sensing overload current in only one load (B). It should be noted that overload protection is not provided in the load (A) circuit, and if needed, must be provided by other means. Also, the sum of the current in circuit A & B must not exceed the contact rating of the device.

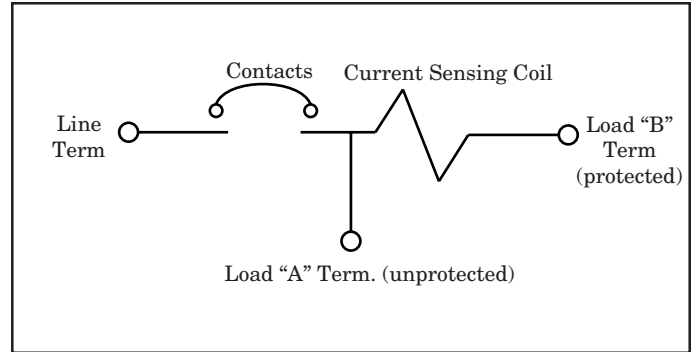

Another application possibility occurs when a voltage coil (rated for line voltage) is used. Here the load (B) terminal is connected in series with a N.O. push-button switch or similar control device. With this, a line voltage pulse through the coil can be used as a means of remotely opening the load (A) circuit. Because the voltage coil is self-interrupting, no additional components, such as auxiliary switches, etc., are needed in the load (B) circuit.

