

Heinemann®
Circuit Breakers

EATON



Series GH

Economical EH-Frame rated at 0.5–100A



Bulletin GH

The EH-Frame breaker with hydraulic-magnetic dependability at competitive prices



Now you can afford a completely magnetic three-pole branch circuit protector for less than you used to spend for a thermal unit.

Heinemann® breakers have proved their ability by performing in "hardship" installations, indoor and out, that require a compact, environmentally stable breaker rated to 100 amperes at 480 V ac.

Because of their ability to furnish both close-rated locked-rotor protection and running overcurrent protection without derating, even under extreme and highly variable ambient conditions, the Series GH3 breakers are performing yeoman service in a variety of industries: air conditioning, electric heating, computer main frame and central processing, transportation and many others.

UL-listed for interrupting capacity up to 14,000 amperes at 480 VAC (UL489)

Precise current ratings

The Series GH3 breaker, because of its fully magnetic current-sensing construction, can be rated in close relation to its load.

Wide range of standard ratings available off-the-shelf

Choice of overload response times

Series GH3 breakers are available in fast, medium and slow response times to fit many momentary overload applications. Each response is inversely proportional to the magnitude of the overload and, as such, is self-adjusting. On overloads of 1000-1400% of the breaker's rating, the time-delay function is bypassed, and the breaker trips instantaneously.

The curves shown indicate the magnitude and duration of overloads which will be tolerated before tripping occurs. By selecting the proper curve, breaker response can be closely matched to the safe operating limits of the equipment or circuitry.

Terminal Types

Standard: front connected, pressure-wire terminals accepting copper or aluminum wire in sizes from #14 to #1. Back connected construction and special terminals are available. Consult factory.

Specifications

Electrical ratings

Standard maximum voltage: Breakers may be used at any 50/60 Hz voltage up to and including 480 V. All breakers will be labeled with the standard voltage unless otherwise specified. (All UL/CSA-listed models must be labeled with the standard maximum voltage of 480 Vac.) Consult factory for DC breakers rated 250 VDC Series up to 700 VDC at 100 A max, non-U/L or CSA.

Standard current ratings: 15, 20, 25, 30, 40, 50, 60, 70, 80, 90 and 100 A at 480 V 50/60 Hz ac.

Special current ratings: Any integral or fractional current rating from 0.5 to 100 A ac. (Ratings below 15 A are not UL/CSA listed.) Interrupting capacities: Listed by UL/CSA for 14,000 A at 480 V, 50/60 Hz, three-phase, at 25% to 30% power factor; 7500 A on ratings below 15 A (non-UL).

Approximate weight: 3.3 lb. (GH3)

Dimensions

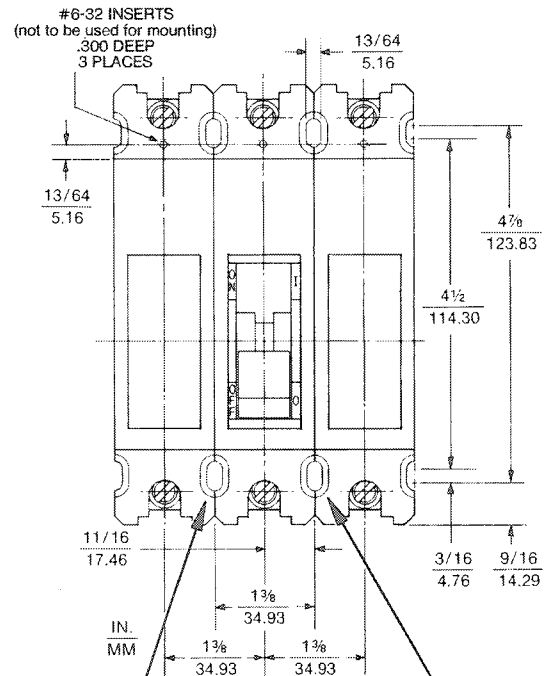
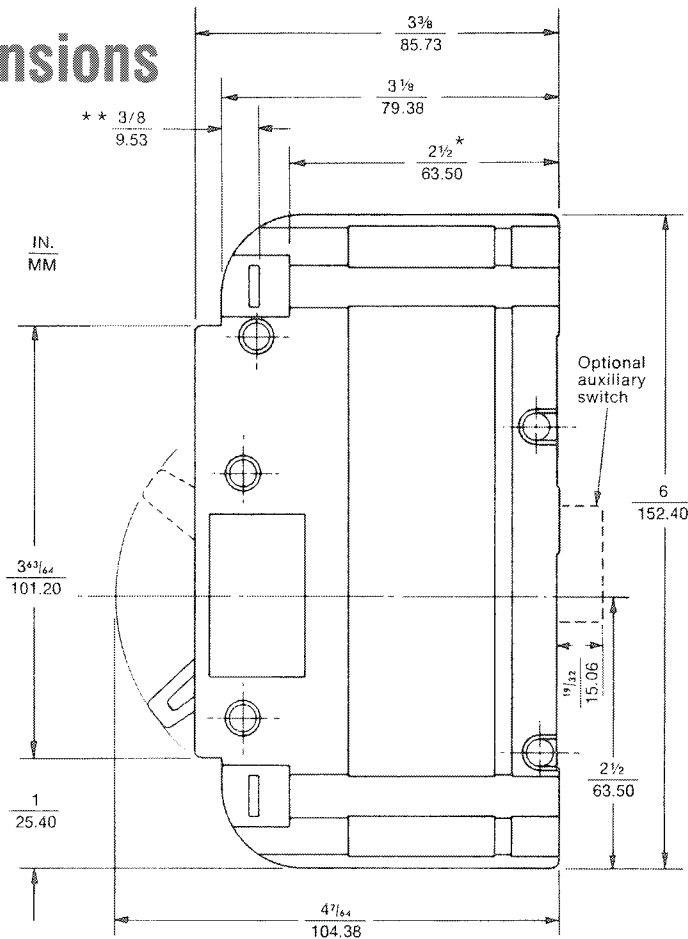

***Mounting Front Connected Breakers**
 Clearance holes for 10-32 screws (4 places)
 Minimum screw length 2 1/2 inch plus panel thickness. Add additional length for screw protrusion behind panel if using screws and nuts.

****Mounting Back Connected Breakers**
 8-32 mounting inserts (4 places)
 Minimum screw length 3/8 inch plus panel thickness.

Note:

Asterisk dimensions indicate minimum mounting screw lengths. Panel thickness must be added to these dimensions.

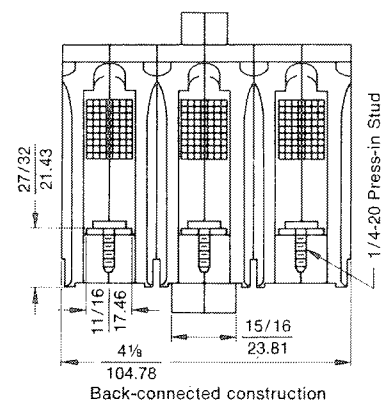
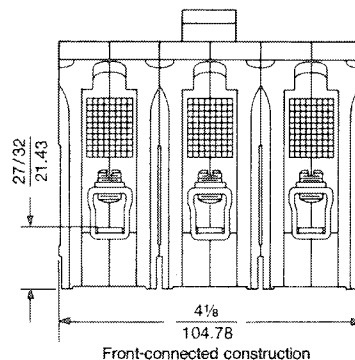

All dimensions are in inches/mm. tolerance $\pm 1/32$ " except to specifying. Final engineering drawings should be made where noted.

Dimensions are given here only as a preliminary guide from the latest Heinemann factory drawings, available on request.

Time Delay Curves and applications

The curves shown indicate the magnitude and duration of overloads which will be tolerated before tripping occurs. By selecting the proper curve, breaker response can be closely matched to the safe operating limits of the equipment or circuitry.

Curve 1 allows the largest and most prolonged overload, needed to prevent nuisance tripping on motor circuits.

Curve 2 a medium delay, accommodates mixed loads consisting of lights, motors, and resistive heating, where the breaker is rated to the wiring instead of to any specific load.

Curve 3 permitting a very brief time delay period before tripping, is used for protection of transformers and electronic circuits.

Curves 10, 20 and 30

High-inrush — Time delays similar to Curves 1, 2 and 3 with high-inrush surge capabilities

Curve 100

High-inrush — For ferro-resonant power supplies, distribution transformers, data processing equipment, etc., which may draw starting surges as high as 3000% normal load. To accommodate brief surges of this magnitude for approximately a half cycle of line current, or 8.3 millisecond (long enough to get the equipment on line without tripping), high-inrush models are available.

Non-time-delay breakers have no deliberately imposed delay, and will trip instantaneously at any load above 120% of rated current

Ambient effect on time delay

Breakers will hold 100% of rated current regardless of ambient temperature.

Time delay will decrease as ambient temperature is raised and increase as ambient is lowered.

Tripping Specifications

All time-delay curves shown are based on the fact that circuit breakers are not preloaded. (Breakers do not carry current prior to application of overload for calibration testing.) Curves are plotted at an ambient temperature of 77°F (25°C), with breakers in the standard wall-mount position.

All circuit breakers shall hold 100% rated load continuously. Breakers for 400 Hz operation may trip between 101% and 150% of rated load; must trip at 150% and above.

Other time-delay circuit breakers may trip between 101% and 125% of rated load; must trip at 125% and above, as shown on the time-delay curve selected.

Non-time-delay circuit breakers may trip instantaneously between 101% and 120% of rated load; must trip instantaneously at 120% and above. Non-time-delay 400 Hz breakers may trip instantaneously between 101% and 150% of rated load; must trip instantaneously at 150% and above.

50/60 Hz Curves

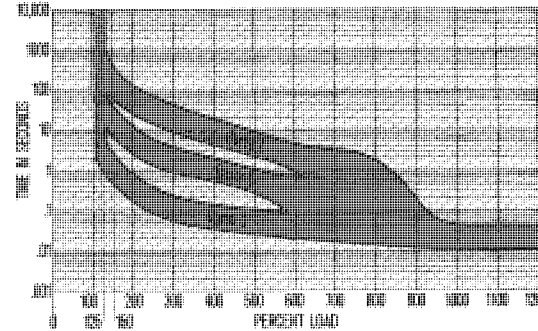

Percent of rated current vs. trip delay at 25° C

%	Curve#	100%	125%	200%	400%	600%	800%	1000%
Delay Max (sec)	1	no trip	880	110	8	4	1.6	0.045
Delay Min (sec)	1	no trip	100	20	4	0.9	0.013	0.010
Delay Max (sec)	2	no trip	90	10.5	1.84	0.64	0.190	0.045
Delay Min (sec)	2	no trip	13	2.1	0.46	0.03	0.013	0.010
Delay Max(sec)	3	no trip	6.4	0.60	0.130	0.075	0.052	0.040
Delay Min (sec)	3	no trip	0.80	0.15	0.032	0.019	0.013	0.010

400 Hz Curves

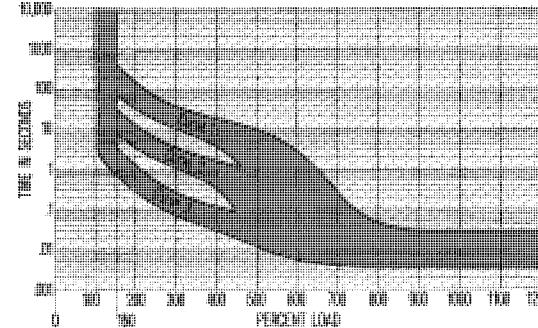

Percent of rated current vs. trip delay at 25° C

%	Curve#	100%	150%	200%	400%	600%	800%	1000%
Delay Max (sec)	1	no trip	400	150	17	2.7	0.50	0.028
Delay Min (sec)	1	no trip	95	35	4.3	0.03	0.008	0.0038
Delay Max (sec)	2	no trip	45	13	1.8	0.40	0.045	0.028
Delay Min (sec)	2	no trip	12	3.8	0.35	0.02	0.008	0.0038
Delay Max(sec)	3	no trip	4.5	0.90	0.13	0.04	0.030	0.028
Delay Min (sec)	3	no trip	0.8	0.023	0.03	0.0065	0.004	0.0038

DC Curves

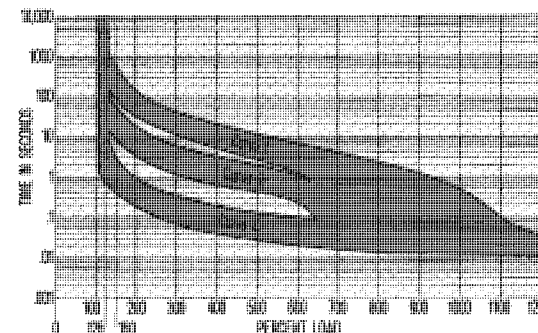

Percent of rated current vs. trip delay at 25° C

%	Curve#	100%	125%	200%	400%	600%	800%	1000%
Delay Max (sec)	1	no trip	1000	100	16	5.2	1.7	0.35
Delay Min (sec)	1	no trip	120	22	4	1.1	0.01	0.008
Delay Max (sec)	2	no trip	90	13	2.4	0.80	0.29	0.055
Delay Min (sec)	2	no trip	12	2.5	0.50	0.19	0.01	0.008
Delay Max(sec)	3	no trip	3	0.65	0.15	0.075	0.047	0.038
Delay Min (sec)	3	no trip	0.44	0.13	0.030	0.015	0.010	0.008

Time delay curves and applications (continued)

60 Hz High-inrush Curve 10

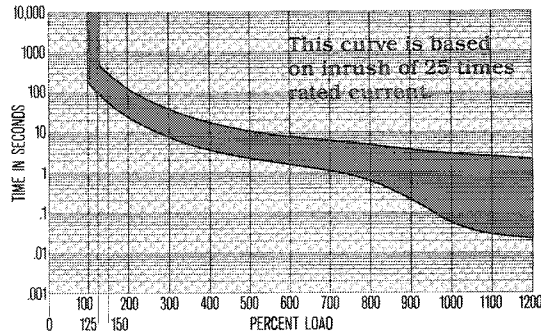

Percent of rated current vs. trip delay at 25° C

%	100%	125%	200%	400%	600%	800%	1000%
Delay Maximum (seconds)	no trip	500	110	16	7	4	2.75
Delay Minimum (seconds)	no trip	80	22	3.6	1.5	0.65	0.05

60 Hz High-inrush Curve 100

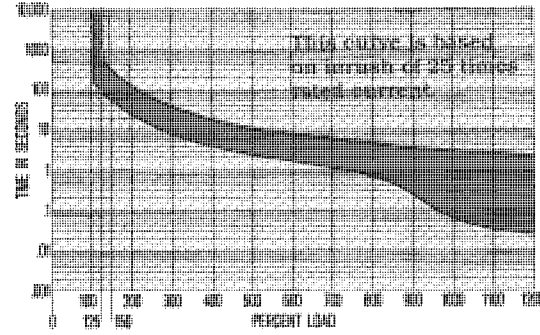

Percent of rated current vs. trip delay at 25° C

%	100%	125%	200%	400%	600%	800%	1000%
Delay Maximum (seconds)	no trip	742	200	38	17	8.5	6
Delay Minimum (seconds)	no trip	130	45	9	4	1.5	.05

60 Hz High-inrush Curve 30

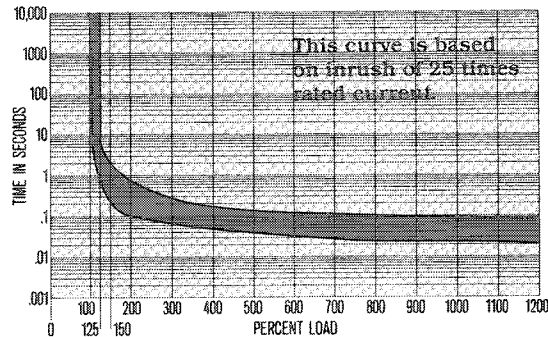

Percent of rated current vs. trip delay at 25° C

%	100%	125%	200%	400%	600%	800%	1000%
Delay Maximum (seconds)	no trip	6.4	0.74	0.16	0.13	0.11	0.097
Delay Minimum (seconds)	no trip	0.70	0.10	0.045	0.030	0.022	0.021

60 Hz High-inrush Curve 20

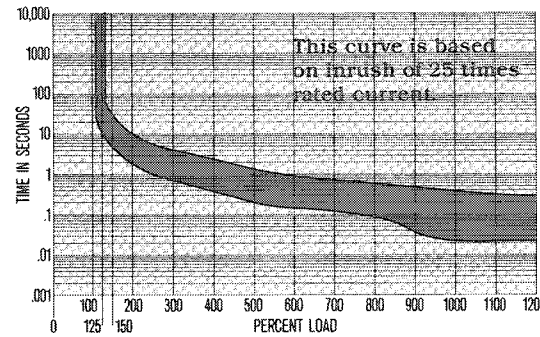

Percent of rated current vs. trip delay at 25° C

%	100%	125%	200%	400%	600%	800%	1000%
Delay Maximum (seconds)	no trip	60	8	2.0	0.80	0.50	0.35
Delay Minimum (seconds)	no trip	8	1.5	0.32	0.14	0.08	0.02

Environmental characteristics

Operating Temperature Range: -40°C to +85°C.

Fungus and moisture resistance is provided in accordance with MIL-STD-202 by treating all ferrous parts with a special moisture resistant finish and by using special springs and fungus-resistant cases, covers, and handles.

Shock tested in accordance with MIL-STD-202, Method 213, Test Condition I (100G's at 6 milliseconds).

Vibration tested in accordance with MIL-STD-202, Method 204, 10-500 Hz, 0.06" total excursion on three mutually perpendicular planes. Shock and vibration tests apply to time delay breakers only and are performed with the units carrying full rated current.

Resistance-impedance

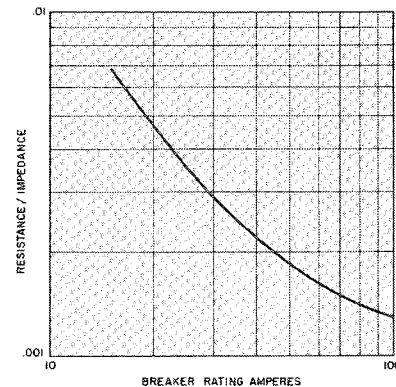

Tolerance Limits

Current (amps)	Tolerance (%)
15 to 59.9	±25
60 to 100	±35

How to order standard Series GH circuit breakers

Note: Standard catalog number must have 18 digits including dashes.
See How to Order non-standard when all poles of a multipole unit are not identical.

GH3— —G3— U— 0015 —02 B
Step 1 Step2a & b Step3 Step4 Step5 Step6

Step 1

GH3—

Series prefix(GH3) include a dash as shown.

Step 2a Table A

—6—

Code	Frequency	Terminal Location
A	50/60 Hz	Back
B	DC	Back
G	50/60 HZ	Front
H	DC	Front

Add a dash before the code letter.

Step 2b Table B

—G3—

Inrush Code	VDE		Internal Circuit Construction	See Notes
	N/A	Std.		
0		No	Switch only (no coil)	
	2	Yes	*Series trip with SPDT aux. switch	1,2,3
	3	Yes	Series trip	3

* On multipole units one aux. switch is supplied. It is located in the left pole when viewed from the front of the breaker. See page 7 for non-standard part number when additional switches or pole locations are required.

Notes:

1. Auxiliary switch is rated for 10.1 amps, 125/250 VAC. Low level switches rated at 0.1 amps, 125 VAC are available under factory assigned part number.
2. Auxiliary switch VDE approved for use in circuits above 42 volts. Not approved for SELV circuits. VDE switch rated at 1 amp, 125 VAC.
3. Inrush construction code 2 and 3 are VDE approved. Codes 8 and 9 are not approved.

Step 3 Table C

U—

Add a dash after single digit UL codes.

UL		Type Approval	Maximum Voltage
Code	Standard		
U	UL-489	Branch Circuit – General Purpose	480 VAC
DU	UL-489	Branch Circuit – Special Purpose	480 VAC
AB	UL-508	Manual Motor Controller	480 VAC
AE	UL-508	Manual Motor Controller	600 VAC

Breakers will be marked with the maximum UL approved voltage.

DC units are not UL approved. Maximum voltage is 250 VDC.

Step 4 Table D

0015

Standard Current Ratings

Current Code	Ampere	Current Code	Ampere
0015	15.00	0050	50.00
0020	20.00	0060	60.00
0025	25.00	0070	70.00
0030	30.00	0080	80.00
0040	40.00	0090	90.00
0100			100.00

For other current ratings consult factory

Step 5 Table E

—02

Time Delay Curves

Code	Inrush Level		Time Delay
	Std.	25x	
—01	x		Long
—02	x		Medium
—03	x		Short
100		x	Motor Start
—10		x	Long
—20		x	Medium
—30		x	Short

See time delay curves on pages 4 and 5 for required delay.

Step 6 Table F

B

Code	Voltage Rating
B	251-600 VAC
D	160-250 VDC
H	VDE 480 VAC, 50/60 Hz

VDE 0660 approval applies to 50/60 Hz constructions listed under VDE column in Table B.

How to order non-standard* Series GH circuit breakers

*Non-standard part numbers may require a factory assigned part number.

GH3 -A2A3A3- DU -40 -02
 Step 1 Step2a & b Step3 Step4 Step5

Step 1

GH3

Series prefix (GH) and number of poles (1-3)

Step 2a Table A

-A2A3A3-

Voltage, frequency and internal circuit for first pole on left as viewed from front of panel, or for all poles if identical, from Tables A and B.

Code	Frequency	Terminal Location
A	50/60 Hz	Back
B	DC	Back
C	400 Hz	Back
G	50/60 HZ	Front
H	DC	Front
J	400 Hz	Front

Step 3 Table C

DU

Code	UL Standard	Type Approval	Maximum Voltage
U	UL-489	Branch Circuit – General Purpose	480 VAC
DU	UL-489	Branch Circuit – Special Purpose	480 VAC
AB	UL-508	Manual Motor Controller	480 VAC
AE	UL-508	Manual Motor Controller	600 VAC

Breakers will be marked with the maximum UL approved voltage. DC breakers are not UL approved. Maximum voltage is 250 VDC. UL approvals apply to GH3 only.

Step 4 Table D

-40

Standard Current Ratings

Ampere	Ampere
15	60
20	70
25	80
30	90
40	100
50	

Other non-listed ratings are available. Consult factory for availability and lead times.

Step 2b Table B

-A2A3A3-

Repeat Step 2 for second and third poles and subsequent poles if different from first. Repeat aux. switch codes when more than one switch is specified (ex. GH2-A2A2).

Circuit Codes			Internal Circuit Construction		See Notes
Inrush	VDE				
N/A	Std.	25x	App.		
0			No	Switch (no overload coil)	
	2	9	Yes	Series trip with standard enclosed SPDT aux. switch	4, 5, 6, 7
	3	8	Yes	Series trip	7
	5		No	Shunt/tap	1, 2
	6		No	Relay-trip	2
12			No	Switch with standard enclosed SPDT aux. switch	
	15	25	No	Du-Con with Shunt/Tap voltage coil	3
	16	26	No	Du-Con with relay-trip voltage coil	3

Notes:
 1. Voltage rated shunt coils trip on line voltage. 2. Contact rating for shunt and relay is 100 amps. 3. Du-Con voltage coils require 30 VA to operate and are rated for intermittent duty. Specify Du-Con voltage rating after part number. A factory assigned part number is required. 4. Auxiliary switch is rated for 10.1 amps, 125/250 VAC. Low level switches are rated at 0.1 amps, 125 VAC are available under factory assigned part number. 5. Auxiliary switch VDE approved for use in circuits above 42 volts. Not approved for SELV circuits. VDE switch rated at 1 amp, 125 VAC. 6. VDE

Step 5 Table E

-02

Time Delay Curves

Code	Inrush Level		Time Delay
	Std.	25x	
-01	x		Long
-02	x		Medium
-03	x		Short
100		x	Motor Start
-10		x	Long
-20		x	Medium
-30		x	Short

See time delay curves on pages 4 and 5 for required delay.

Heinemann Circuit Breakers Series GH

For the widest selection of circuit protection, from 0.01 to 700 amperes, look to Heinemann.

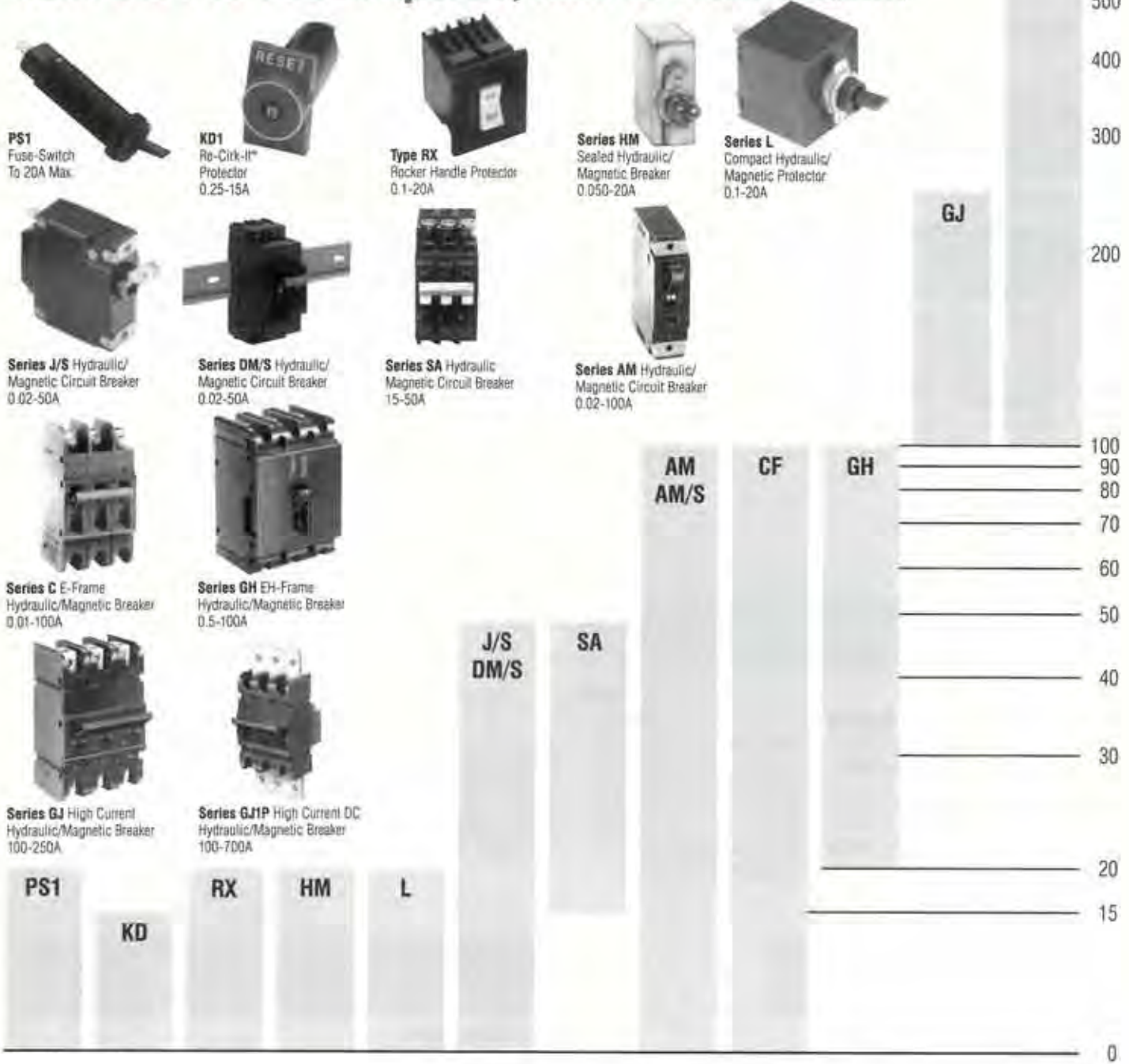

For warranty information, see CMCO Bulletin C-C7.0.

Products described by this catalog are covered by one or more United States of America patents and appropriate foreign patents, where applicable.

EATON

Printed in U.S.A.
DI-135
R5965M93