

# MAAOA/215-Series

## Toggle Switches

The MAAOA/215-Series toggle switches are single pole, AC rated at 20 amps and 125 VAC. These switches are snap-in mounted, with a phenolic toggle and base, and are suitable for high ambient temperature applications including Coffee Makers and Food Warmers.



**Carling Technologies®**

Innovative Designs. Powerful Solutions.

Innovative Designs. Powerful Solutions.

Carling Technologies, Inc.  
60 Johnson Avenue • Plainville, CT 06062-1177  
Phone: (860) 793-9281 • Fax: (860) 793-9231  
Email: [sales@carlingtech.com](mailto:sales@carlingtech.com) • [www.carlingtech.com](http://www.carlingtech.com)

### Dielectric Strength

UL/CSA: 1000V - live to dead metal parts & opposite polarity

### Electrical Life

25,000 cycles

### Mechanical Life

100,000 cycles

### Operating Temperature

32°F to 185°F (0°C to 85°C)

**MAAOA** - **BL** / **ON-OFF**

<sup>1</sup>  
Base Part Number

<sup>2</sup>  
Color

<sup>3</sup>  
Legend

#### 1 BASE PART NUMBER: SERIES/CIRCUITRY/RATING/TERMINATION

	10A 250 VAC, 20A 125 VAC, 1/2 HP 125-250 VAC	2.50 Tabs	Screw Terms.	Wire Leads
Single Pole				
On-Off	<b>MAAOA</b>	<b>215</b>	<b>215A</b>	
(On)-Off	<b>MM-021</b>	-	-	

#### 2 BASE & ACTUATOR COLOR

<b>BL</b>	Black	<b>BN</b>	Brown
-----------	-------	-----------	-------

#### 3 LEGEND<sup>1</sup>

On-Off

**Notes:**

Panel Cut-Out recommendations: For sheet metal panels, switch must enter panel in same direction as the punch. (Burr on bottom.) Test cut hole in actual material.

1 Imprinting is available. ON-OFF legend is not standard and must be specified after color. If not specified, switch will be manufactured with no legend.

( ) Indicates momentary function.

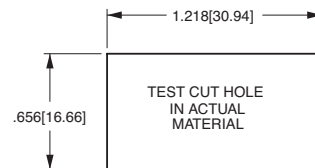
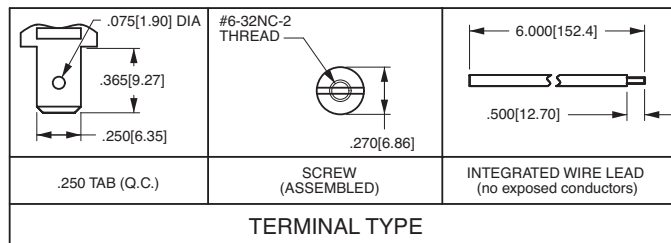
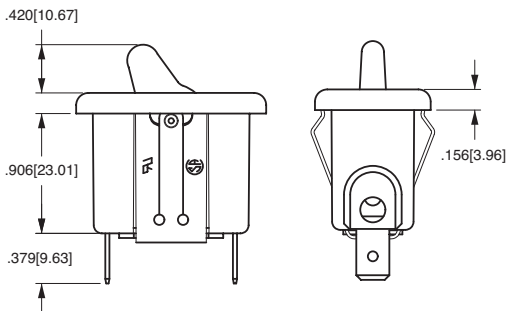

**MOUNTING HOLE**  
Panel Thickness: .030[.762] min - .090 [2.28] max.  
Specific cutout dimension range dependent on panel thickness and material.